



PENETRON[®]
TOTAL CONCRETE PROTECTION

PENEBAR

Expanding waterstop for concrete joints



Renovation without interruption:
Hydro Electro Station,
Saratov, Russia
First built in 1967, the Saratov dam is 725 m (793 yards) long and 40 m (132 feet) tall. The concrete structures were completely renovated with a full line of PENETRON products: PENETRON, PENEKRETE MORTAR, PENEBAR waterstops and PENEPLUG – to complete emergency repair work in the lift shafts without interrupting lift operations.

Keeping moisture out, chill out: DNA Camperdown Apartments, Camperdown NSW, Australia
The low-rise apartment buildings encircle landscaped gardens with terrace-style apartments that provide lots of natural light and views of downtown Sydney. PENETRON ADMIX was used to treat the lift pits, the oversized on-site detention tank/podium and all three tower roof slabs to provide waterproofing protection and enhanced concrete durability. PENEBAR SW was used on all concrete joints.



Enhancing the performance of any waterproofing system

PENEBAR SW: Expanding waterstop for concrete construction joints

Designed to stop water ingress through cast-in-place concrete construction joints, PENEBAR SW (“SWellable”) is an expanding strip waterstop that expands to form a positive seal against the concrete when in contact with water. PENEBAR SW provides an optimal upgrade over passive PVC and rubber dumbbell waterstops by eliminating the need for special parts, tie-ins, split-forming and seam welding.

PENEBAR SW waterstops enhance the performance of any waterproofing system by sealing concrete exposed to water ingress. It has been used successfully around the world, in a wide range of construction projects.

PENEBAR SW before hydration

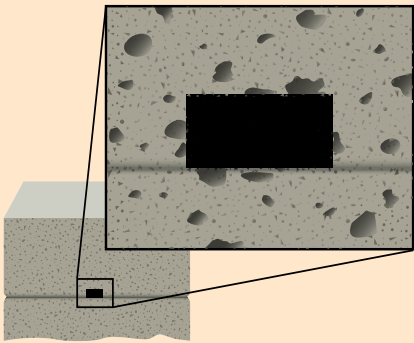

Expanded PENEBAR SW after hydration



PENEBAR SW in action:

Before the concrete pour, the waterstop is pressed on to the concrete surface (see left box in diagram). Upon contact with water, the swelling properties of PENEBAR SW (right box) enable it to seal the cracks and voids found in concrete joints, even under high hydrostatic pressure, continuous immersion and wet/dry cycling.



Close-up of a concrete cross-section showing the swelling properties of PENEBAR SW waterstop.

All of our waterstop products are designed to work as stand-alone products as well as with the family of crystalline technology products in the PENETRON System. When used together with PENETRON crystalline products, our waterstops become an integral part of a highly effective waterproofing solution – and a time-saving and cost-effective solution for durable and waterproof concrete structures.

**When you need
rapid expansion performance**

PENEBAR SW-45 Rapid

Recommended for non-moving cold joints in building foundations, slabs, retaining walls and storage tanks, PENEBAR SW-45 Rapid is a fast-acting, concrete joint water-stop designed to expand rapidly when exposed to water.



This unique joint-healing material conforms well to the underlying substrate and features optimized expansion characteristics that make it the preferred solution for protection of construction projects exposed to salt water or high hydrostatic pressure.

Wide range of applications

PENEBAR SW-45 is applied to all non-moving concrete joints that need protection from moisture ingress. Typical projects include: base slabs, foundations, retaining walls, water retaining structures, tunnels, pipes, penetrations, box culverts, etc.

Deep and dry tunnels: Baku Subway Station, Baku, Azerbaijan

The renovation of the Baku subway system included extensive repair work to the subway's leaking walls and ceilings, including the electric maintenance room. Restoration of the upper layers of concrete was done with PENECRETE MORTAR, PENEBAR and PENETRON to completely arrest penetration of the underground water.





Keeping water out – and in: Modera Coral Gables, Miami, Florida USA

A luxury apartment complex with 237 units and extensive exterior retail areas, the Modera Coral Gables has six residential floors above three levels of parking and a large pool on the fourth floor. The construction site was 1.6 m (5 feet) under the water table, presenting a challenge to the builder. PENETRON technology (including PENEBAR and PENETRON ADMIX) was used in all below grade structures, the three-level parking garage, the on grade mat slab and perimeter walls, and the 4th-floor pool (see photo).

Expansion rate when immersed in fresh water

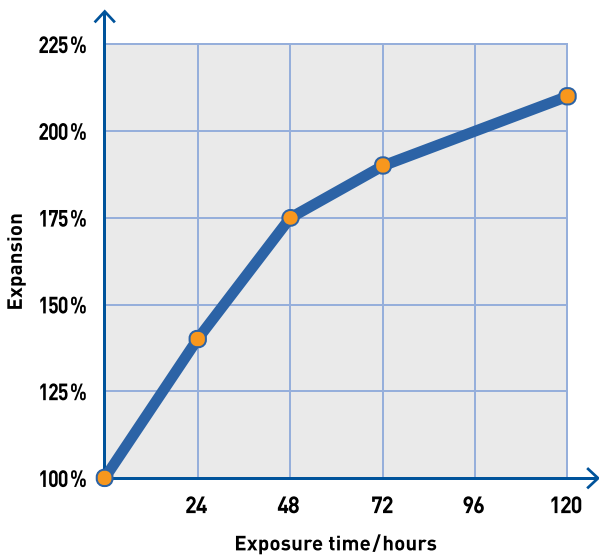

Expansion rate when immersed in salt water

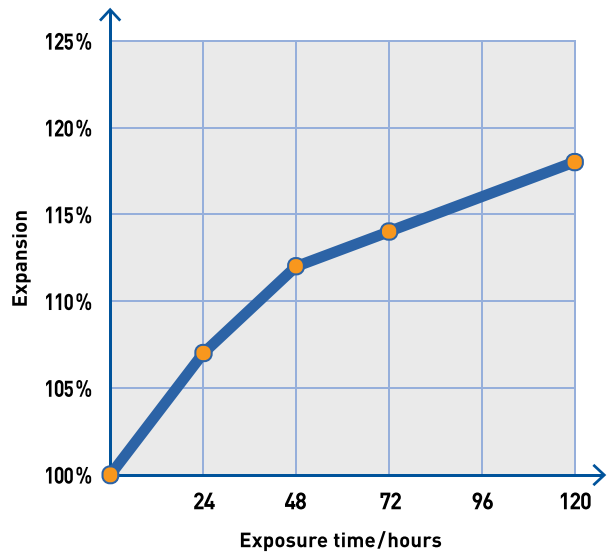

The benchmark in controlled expansion for waterstop applications

PENEBAR SW-55



PENEBAR SW-55 is a versatile concrete joint waterstop that expands in a controlled fashion when exposed to water.

Made of a butyl rubber base infused with bentonite (and coated with a delay mechanism), it creates a controlled, moisture-activated, compression seal. This characteristic helps avoid internal pressures possible in cast-in-place applications, and also any potential spalling in foundations and wall structures.

Its superior ability to expand and seal concrete joints allows it to replace the more passive tied-in PVC waterstop systems and eliminate welding irons, split-forming and special shapes.

Ideal for a range of project types

PENEBAR SW-55 is applied to all non-moving concrete joints that need protection from moisture ingress. Typical projects include: underground structures, basements, precast panels, tunnels, new concrete onto old concrete, manholes, lift pits, retaining walls, storage tanks, concrete pipes, car parks etc.

Expansion rate when immersed in fresh water

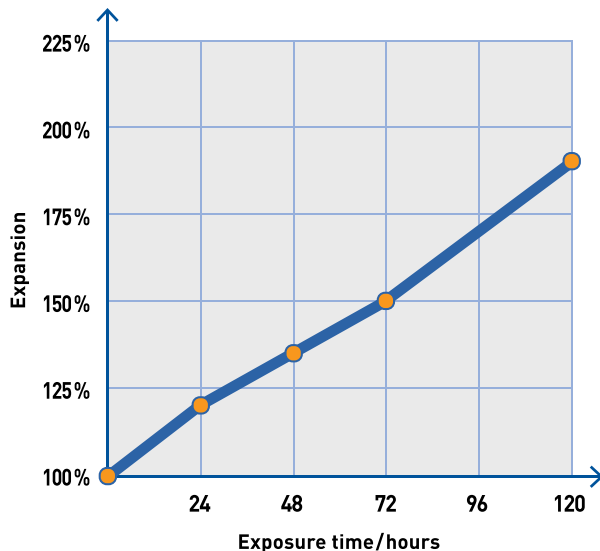

Expansion rate when immersed in salt water

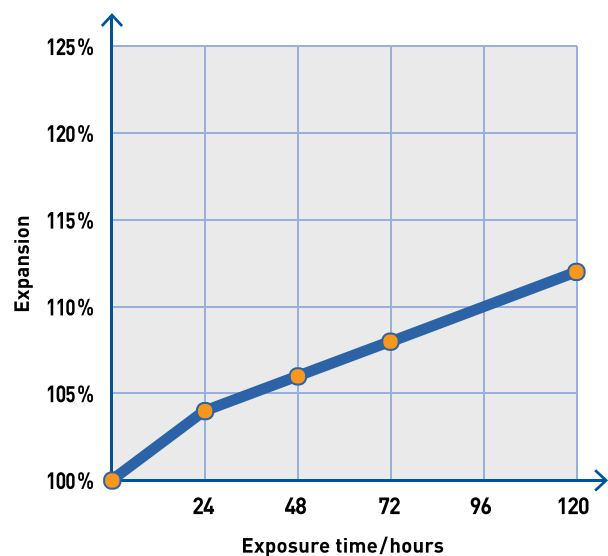

What is controlled expansion?

Controlled expansion allows PENEBAR SW-55 to avoid some of the problems that have been associated with traditional waterstops on many building sites;

- It does not expand prematurely and does not absorb any water from fresh concrete poured against it
- It will not expand to a point where the hydration process causes it to disintegrate and hence will not be washed away when subjected to a constant water flow
- It will not cause excessive internal pressure in the concrete

Advantages of controlled expansion:

- Concrete is allowed to gain full strength before expansion
- Built-in delay system prevents premature expansion
- Does not disintegrate over time
- Not affected by repeated wet and dry cycles
- Easy to apply to rough concrete surfaces
- Can be used in horizontal and vertical joints



Stylish, “green” & waterproof: Alice Lane Office Towers, Johannesburg, South Africa

The 18-floor, energy efficient Alice Lane Office Towers in the prestigious Sandton area feature two sculpted towers linked by a vertical atrium; an extensive ‘greenscape’ is surrounded by reflective ponds. Underneath is a 6-floor parking garage. The PENETRON System, including PENEBAR waterstops, was specified for the ponds and all water tanks.



Guaranteed durability: Opera and Ballet Theatre, Saransk, Russia

This comprehensive renovation replaced the original Opera and Ballet Theatre built over 75 years ago. Project engineers applied waterproofing materials (including PENEBAR waterstops, PENEPLUG and PENECRETE MORTAR) to prevent any further leakage in the foundation.

Start out with the right primer

PENEBAR PRIMER



PENEBAK PRIMER is designed to be used with all PENEBAK SW products and enhances the bonding between the pre-formed PENEBAK SW sealants and concrete surfaces. It aids in the installation process by ensuring the proper adhesion and performance of the waterstop.

PENEBAK PRIMER can be applied quickly and conveniently at the job site with a simple brush application. The primer should be applied to the substrate (carefully brush off dust and debris first) prior to installation of the PENEBAK SW preformed joint sealer. After allowing the PENEBAK PRIMER to dry until tacky to the touch, apply the PENEBAK SW along the area where the primer was applied. Always use PENEBAK PRIMER to prevent the PENEBAK SW waterstop strip from moving during concrete pouring. For vertical surfaces, nails may be used to hold the strip in place.



Built on dry foundation: Sunway Nexis, Kota Damansara, Petaling Jaya, Malaysia
This mixed development combines retail, commercial and residential areas, including a 20-floor home/office building and 2-level basement parking garage. PENETRON ADMIX was used to protect 4,800 m³ (6,300 yd³) of basement concrete and 1,100 meters (3,600 feet) of PENEBAK SW-55 were installed to seal construction joints.





PENEBAR PRIMER properties

Storage/shelf life	12 months when stored in a dry, enclosed area off the ground, between 10–32°C (50–90°F) and in unopened, undamaged pails.
Storage temperature	Minimum: 4°C (40°F), maximum: 40°C (105°F). Product should not be allowed to freeze.
% solids	20% minimum
Solvent type	Water
Dry time 25°C (77°F)	10 minutes
Dry time 4°C (40°F)	60 minutes
Clean-up	Soap and water
Application temperature	Minimum: 4°C (40°F)
Surface when dry	Tacky

Managing the water supply: Taboada Water Treatment Plant, Callao, Peru

This new plant significantly boosts sewage treatment capacity in Lima and the port of Callao, and will ensure clean beaches on the Pacific Ocean coast and reduce pollution in the Rimac River. It serves over 4 million residents and with a maximum capacity of 1.8 million m³ (2.3 million yd³) per day, is the largest water treatment facility in South America. PENEBAR SW-45 was used in all construction joints of this project (together with other components of the PENETRON System) to protect and waterproof the concrete structures in the water treatment plant.



PENEBAR PRIMER is applied first to the area where the waterstop is to be placed. It is quickly and conveniently applied at the job site by a simple brush application.

**Convenient,
effective, long-lasting**

Application instructions for PENEBAR waterstops

PENEBAR SW is applied to vertical and horizontal concrete construction joints, new & existing structures, irregular surfaces, and for wall penetrations (including plumbing and electrical conduits). PENEBAR is especially effective for hydrostatic conditions.

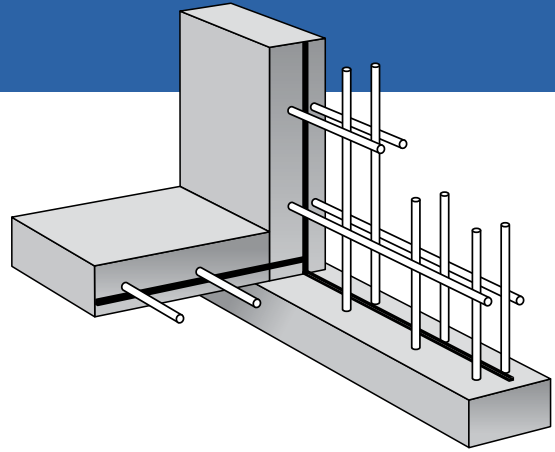

In this cross-section of both horizontal and vertical joints, PENEBAR SW is installed in and along the joint after the first concrete pour and just before the second pour.

step **1**

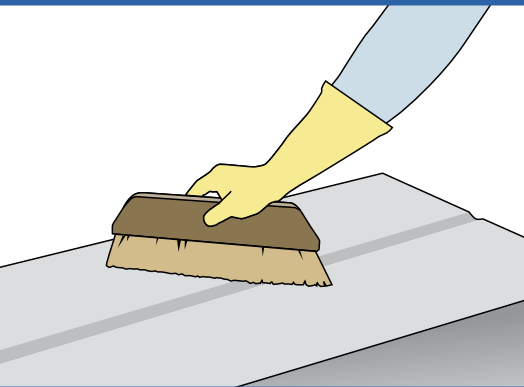

Clean Surface

The concrete surface should be clean, smooth, dry, and cured for a minimum of 24 hours prior to applying PENEBAR PRIMER. Do not install PENEBAR SW in standing water.

step **2**

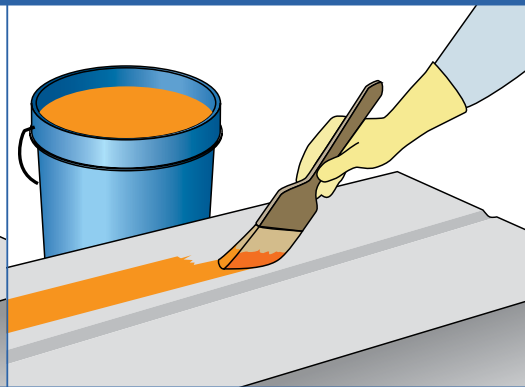

Applying the adhesive

Apply a 5 cm (2") wide coat of PENEBAR PRIMER along the joint and allow to dry until tacky to the touch before applying PENEBAR SW. Always use PENEBAR PRIMER to prevent PENEBAR SW from moving during concrete pouring. For vertical surfaces, nails may be used to hold the product in place. (Application ratio: 3.8 l/1 gallon to 240 m/787 feet of PENEBAR SW)

step **3**

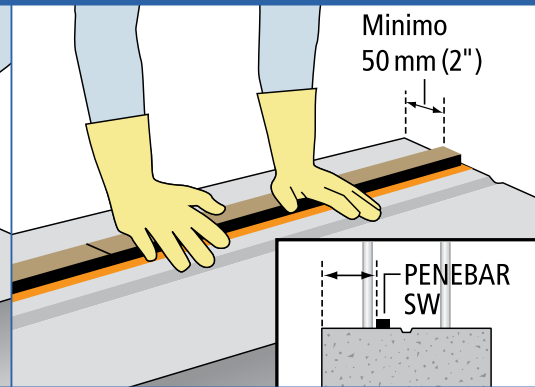

Place the waterstop

With the heel of the hand, press a continuous bead of PENEBAR SW firmly into position over the primed area. PENEBAR SW should be placed at least 50 mm (2") inside the concrete. For pipes and other structural penetrations, cut PENEBAR SW to the measured length and place around the penetration. On rough and irregular surfaces, ensure that PENEBAR SW is directly on the substrate.

Typical PENEBAR SW applications

PENEBAR SW is used for typical construction joints featuring the mandatory 75 mm (3") of concrete coverage.

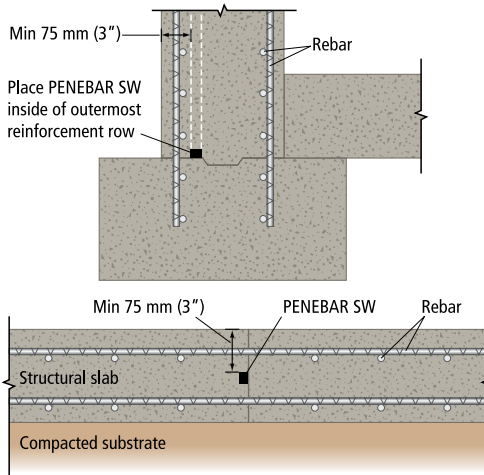

PENEBAR SW is placed in construction joints that have a mandatory 50 mm (2") of concrete coverage.

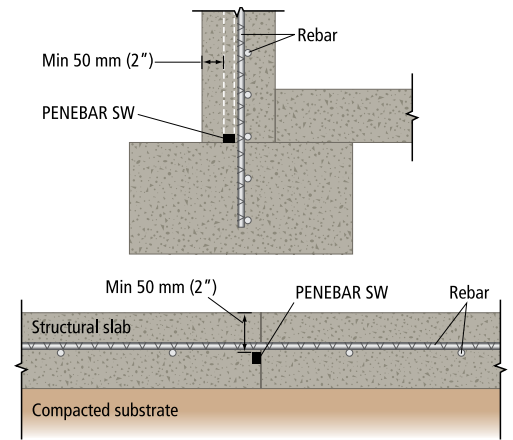

step 4

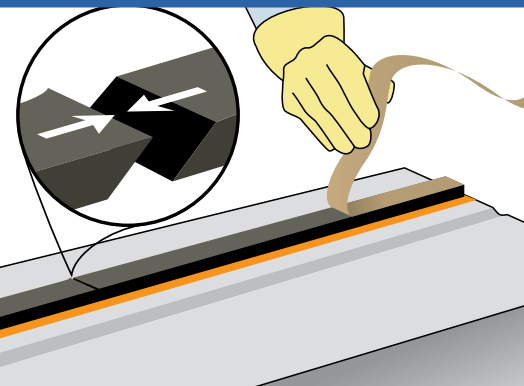

Butt coil ends together at a 45° angle

Peel the protective backing from the exposed side of the installed PENEBAR SW and cut each end at opposite 45° angles; tightly butt the ends together with no separation and no air pockets to form a continuous water-stop. Do not overlap the ends of the waterstop.

step 5

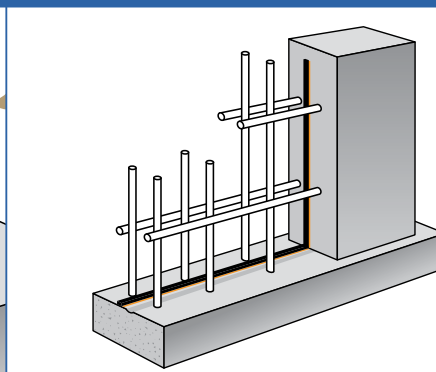

Pour concrete

Pour the concrete as normal. Follow standard concrete placing procedures from here onwards.

Additional considerations



- PENEBAR SW should be placed at a minimum depth of 50 mm (2") inside the concrete.
- When used on pipes and other structural penetrations, PENEBAR SW should be cut to the measured length and placed around the penetration.
- On rough and irregular surfaces, always ensure that PENEBAR SW remains in direct contact with the substrate.

PENEBAR SW

PENEBAR SW waterstops are typically applied to both horizontal and vertical non-moving, concrete construction joints. As a versatile waterproofing solution, they are ideal for further applications such as pipe penetrations and pile caps.

An effective stand-alone waterstop... or part of a system

The PENEBAR SW waterstop products are designed to work seamlessly as stand-alone products—or combined with the PENETRON System. When used together with PENETRON crystalline technology, PENEBAR SW waterstops offer a comprehensive, time-saving and cost-effective solution for durable and waterproof concrete.

This System has been proven effective on countless major projects worldwide thanks to the excellent performance of PENETRON products and our team of experts.

With metal sleeve

Pipe penetrations: Install PENEBAR SW around all single/multiple pipe penetrations (either poured-in-place or with a sleeve). The waterstop should be installed on the outer diameter of each pipe as well as on any construction joints. Sleeves should also have the waterstops around the outer diameter, with another PENEBAR SW strip between the sleeve's inner diameter and the pipe, with continuous contact along both surfaces.

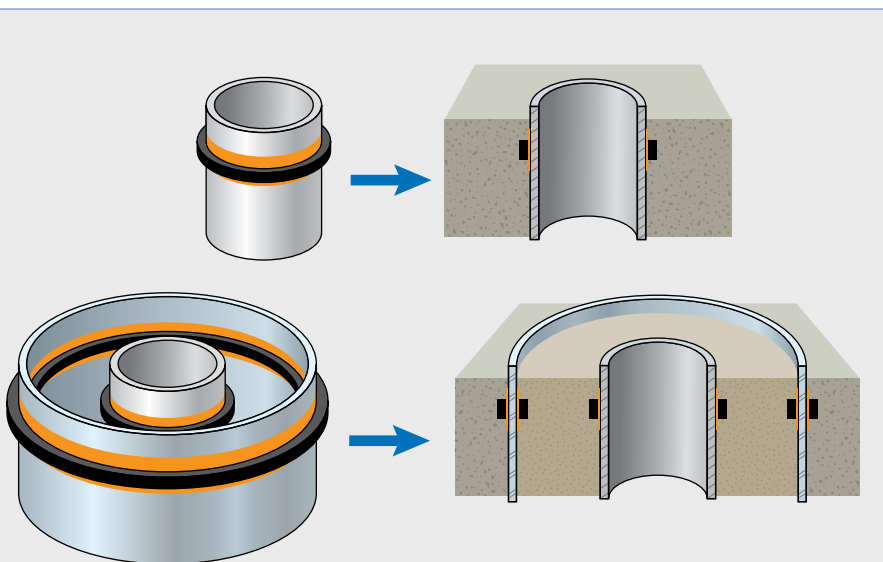

PENEBAR for metal-reinforced pile caps

Install PENEBAR SW around the pile cap and grade beams (non-contacting) above the layer of exterior waterproofing to encircle all metal reinforcement rods extending out of the pile caps.

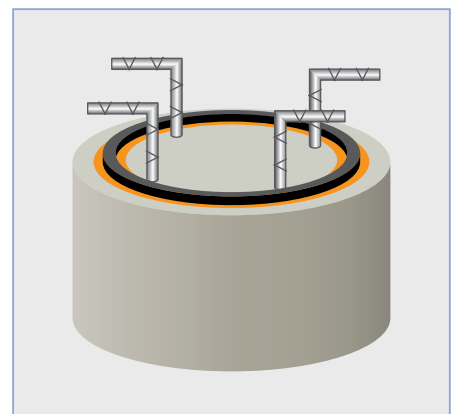

More than a product

As part of the PENETRON System, our PENEBAR SW waterstops are effective as stand-alone products but also work with our crystalline durability products – such as PENETRON ADMIX – to seal construction joints and wall penetrations against water ingress, even under high hydrostatic pressure. Concrete treated with PENETRON ADMIX provides a complete waterproofing solution.

PENETRON works with clients to develop solutions that meet the specific demands of a particular job site. Our world-class products are supported by years of experience, a global network of specialists and proven expertise in optimizing concrete solutions.

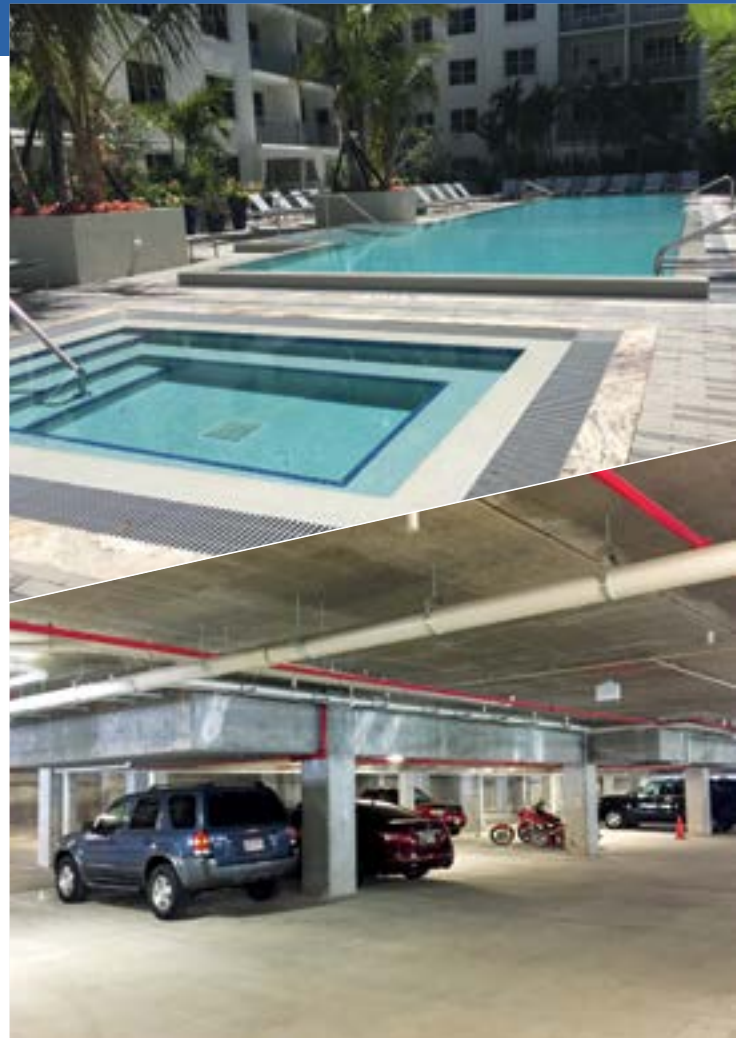

Dry & durable, above & below: The Manor, Lauderdale by the Sea, Florida USA

Set directly on top of the parking area, the pool shell and terrace were treated with PENETRON ADMIX and all construction joints were sealed with PENEBAR SW-55 to ensure that no water would ever seep into the parking area.

Encircling pile cap metal I-beam

PENEBAR for pile caps: Install the PENEBAR SW around the contour of the I-beam in the pile cap to create a separate waterstop layer. If needed, also encircle all metal reinforcement rods that extend out of the pile cap.

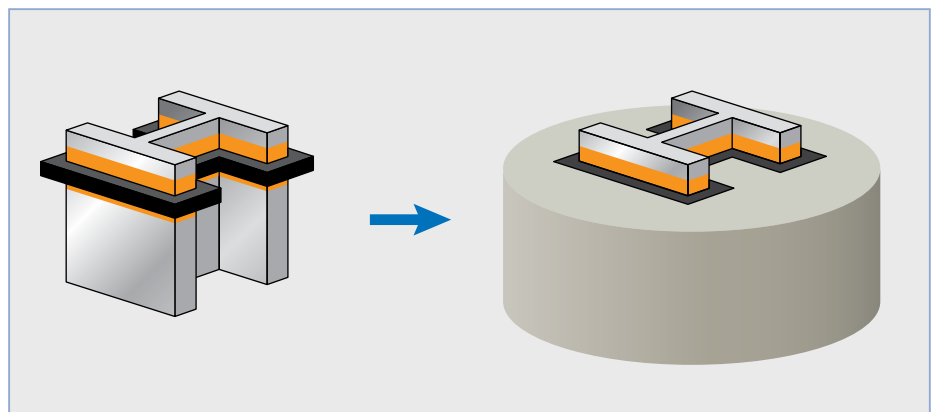

Comprehensive quality control

We test what we sell – and keep testing

All of our products are tested in the lab and the field. PENEBAR waterstop products undergo constant testing and critical evaluation to ensure the consistency of results and performance. Our production facilities (ISO 9001 certified) maintain comprehensive manufacturing and batch lot controls and are outfitted with state-of-the-art equipment to ensure consistent quality control.



Adding capacity & durability: Terminal 3, Guarulhos International Airport, São Paulo, Brazil
The largest airport in South America recently underwent major infrastructure upgrades to handle about 60 million passengers per year. Terminal 3 was added for the 2014 FIFA World Cup. PENEBAR SW-55 was used to seal the concrete joints and PENETRON ADMIX was used to treat the basement slab, both were used to protect against water penetration.

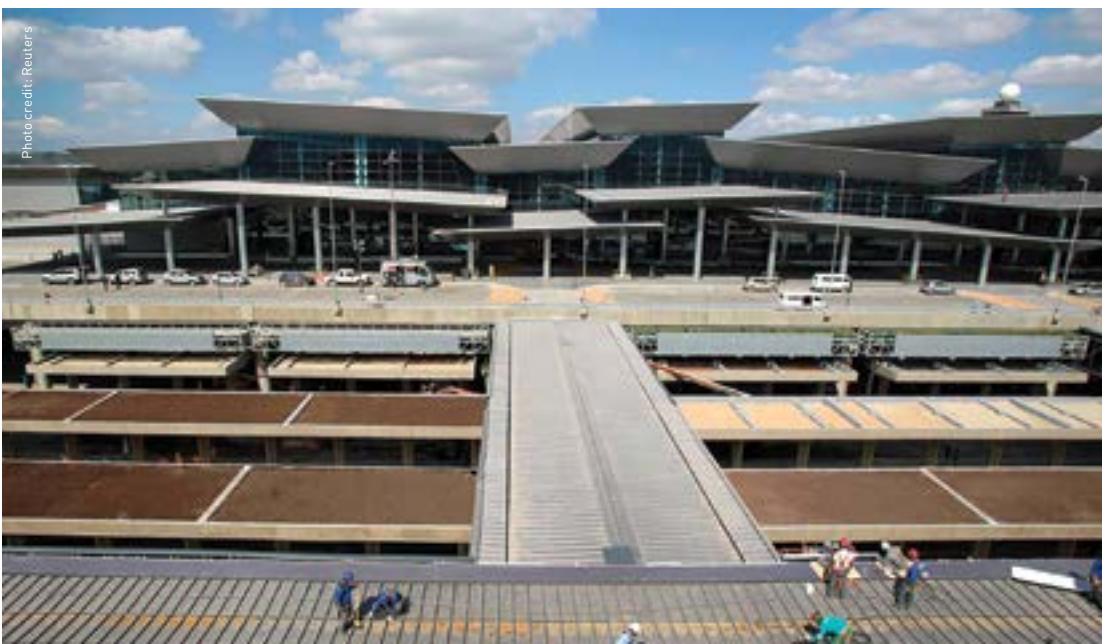

Designed for durability

PENEBAR SW: physical properties

Property	Test standard	PENEBAR SW-45 & SW-55
Color		Black
Specific gravity	ASTM D71	1.55 ± 0.05
Volatile matter	ASTM D6	1% maximum
Penetration, 150 g cone 25 °C (77 °F); 5 seconds	ASTM D217	40 ± 5 mm
Application temperature range	-23 °C to 38 °C (-10 °F to 100 °F)	
Service temperature range	-34 °C to 82 °C (-30 °F to 180 °F)	

Caution PENEBAR SW is not an expansion joint sealant. It should be used in non-moving joints only. PENEBAR SW should be applied the same day as the primer adhesive is applied. Do not remove separation paper from PENEBAR SW until just prior to the concrete pour. Store PENEBAR SW in a cool, dark, and dry place.

Type A “Standard” packaging

- Size: 6 rolls,
19 mm (0.75”) x 25 mm (1”) x 5 m (16’) each
- 30 m (99’)/box
- 45 boxes/pallet = 1,350 m (4,430 feet)
- 10 pallets/6 m (20’) container =
13,500 m (44,300 feet)

Type B “Slimline” packaging

- Size: 6 rolls,
9 mm (0.35”) x 25 mm (1”) x 4 m (13’) each
- 24 m (79’)/box
- 72 boxes/pallet = 1,728 m (5,670 feet)
- 10 pallets/6 m (20’) container =
17,280 m (56,700 feet)



PENEBAR SW: Expanding concrete waterstops

PENEBAR waterstops have been proven effective in countless major projects worldwide. The performance and reliability of our waterstops have firmly established the company as the industry leader.



With locations in all key markets, including facilities in Asia, Europe, North America, Middle East and South America, PENETRON offers products and technical support around the world through a comprehensive network of distributors.



PENETRON International
www.penetrton.com

Phone +1 631 941 9700
Fax +1 631 941 9777
Email info@penetrton.com